

JABSCO® PUMPS

MODELS: 7120-9001 7320-9001

*Bronze Self-Priming
Flange-Mounted Model
For Chrysler M30 Sea-V V-8 Marine Engine*

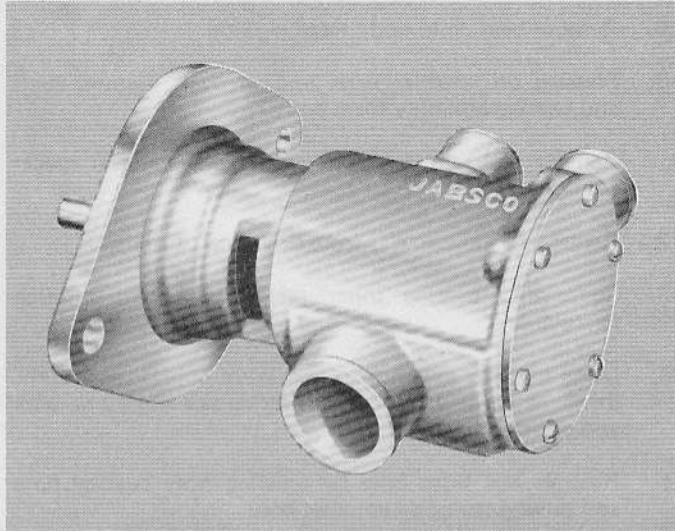

OPERATING INSTRUCTIONS

1. **INSTALLATION**—Model 7120-9001 will operate in clock-wise rotation. For opposite rotation, use Model 7320-9001. Both are used for engine cooling on Chrysler M80 Sea-V engines.
2. **SELF-PRIMING**—Prime at low or high speeds. Be sure suction lines are air-tight or pump will not self prime.
3. **RUNNING DRY**—Unit depends on liquid pumped for lubrication. **DO NOT RUN DRY** for more than 30 seconds. Lack of liquid will burn the impeller.
4. **TEMPERATURES**—Standard impeller is designed to handle liquid temperatures between 45° - 180° F.
5. **FREEZING WEATHER**—Drain unit by loosening the end cover. The following anti-freeze compounds can be used without any adverse effects to the impeller: Atlas "Permaguard", DuPont "Zerex" and "Telar", Dow Chemical "Dowguard" and Olin Mathison "Pyro". Most methyl alcohol (methanol) based anti-freeze can be used. **DO NOT USE PETROLEUM BASED ANTI-FREEZE COMPOUNDS OR RUST INHIBITORS.** NOTE: Our laboratory tests indicate no adverse effects to the JabSCO neoprene compound using "DuPont No. 7" or "Lazy-Way" rust inhibitors.
6. **GASKET**—Use standard pump part. Thicker gasket will reduce priming ability. A thinner gasket will cause impeller to bind.
7. **SPARE PARTS**—A JABSCO Service Kit 90111-0001 should be kept on hand to service all but the most badly worn pumps.

SERVICE KITS

PUMP MODEL NUMBER		90111-000
7120-9001	}	
7320-9001		
Service Kits contain: Impeller, seal and gasket.		

DESIGN FEATURES

BODY	Bronze Construction
IMPELLER	JabSCO Neoprene Compound
SHAFT	Naval Brass
SHAFT SEAL	Mechanical Face Type
WEARPLATES	Replaceable
PORTS	3/4" Dual Discharge (Hose Connection)
	1 1/4" Single Inlet (Hose Connection)
WEIGHT	5 1/2 lbs. (approximately)

CROSS SECTION

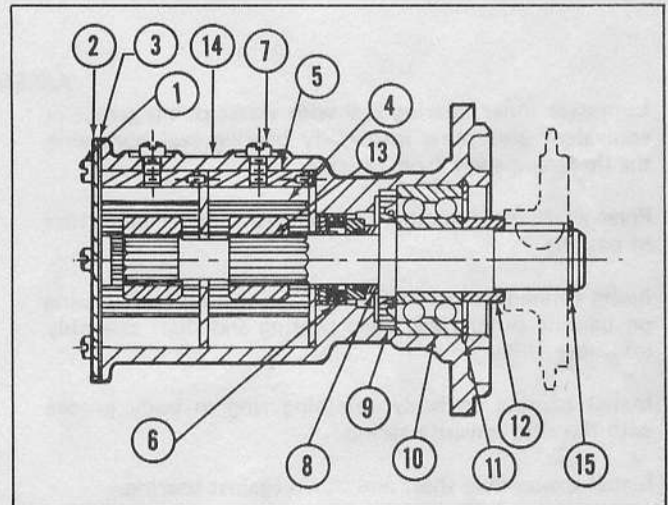

PARTS LIST

KEY	PART NUMBER	DESCRIPTION	QTY. REQ.
1	9100-0020	Screw (End Cover)	6
2	7125-9000	End Cover (Model 7120F)	1
	7325-9000	End Cover (Model 7320F)	
3	3298-0000	Gasket	1
4	1210-0001	Impeller	2
5	7607-0000	Cam & Wearplate Assembly	2
6	96080-0080	Seal Assembly (Complete)	1
7	91003-0010	Screw (Cam)	2
8	9277-0000	Seal Seat Spacer	1
9	913-0000	Bearing Seal	1
10	92600-0060	Ball Bearing	1
11	91701-1850	Retaining Ring	1
12	7126-0000	Spacer	1
	7127-0000	Shaft	1
14	7124-9000	Body (Model 7120F)	1
	7324-9000	Body (Model 7320F)	
15	91700-0750	Retaining Ring (Shaft)	1
16	91401-0100	Key (Not Shown)	1

JABSCO PRODUCTS ITT
Form 43000-0218 Rev. 8-76

MODELS: 7120-9001 & 7320-9001

SERVICE INSTRUCTIONS

DISASSEMBLY

1. Remove end cover screw, end cover and gasket.
2. Remove front impeller by grasping across hub of impeller with water pump pliers.
3. Loosen front cam screw, tap screw to loosen cam, remove screw and cam. (Clean off Permatex).
4. Remove center wearplate.
5. Remove bottom impeller by grasping opposite blades with regular pliers.
6. Loosen back cam screw, tap screw to loosen cam, remove screw and cam. (Clean off Permatex).
7. Remove back wearplate.
8. NOTE: For seal replacement only at this point of disassembly.
 - A. Insert a screwdriver in each opening of drain area between shoulder of shaft and seal seat spacer, using lever action against the seal seat spacer, force seal forward into impeller bore.
9. Remove bearing to body retaining ring.
10. Pressing on impeller drive end of shaft, remove shaft and bearing assembly from body.
11. Remove seal seat, seal seat gasket and seal seat spacer from shaft.
12. Remove key and spacer from drive end of shaft.
13. Supporting bearing inner race, press shaft through bearing.
14. Using extreme care not to mar body bore, insert screwdriver between O.D. of inner bearing seal and pump bore and pry out the seal.
15. Remove seal from bore by pressing from bearing bore end toward the body impeller bore.

ASSEMBLY

1. Lubricate inner bearing seal with water pump grease or equivalent and press into body bearing seal bore with the lip facing away from bearing.
2. Press shaft into bearing. Use care to support inner race of bearing.
3. Insert splined end of shaft into bearing bore and pressing on bearing outer race, press bearing and shaft assembly into bore.
4. Install bearing to body retaining ring in body groove with flat side toward bearing.
5. Install spacer over shaft and down against bearing.
6. Install key in shaft.
7. Slide seal seat spacer over shaft and down against shaft shoulder.
8. Slide seal seat and gasket assembly with rubber facing inward over shaft and down against seal seat spacer. Lubricate with water (do not use oil) to ease assembly. CAUTION: Use care not to scratch or mar seal seat face.
9. With carbon facing in toward seal seat, press seal into bore. CAUTION: Press on outermost edge of seal to prevent damage and press flush with bottom of body impeller bore.
10. Install bottom wearplate in bottom of impeller bore.
11. Permatex top side of cam and cam screw threads. Line up pins in cam with holes in wearplate. Install cam and secure with cam screw. NOTE: Hold cam in place during final tightening of cam screw to insure proper seating of the wearplate.
12. Lubricate impeller bore lightly with water pump grease in the bottom area and with a rotary motion, install the bottom impeller until it is seated against the wearplate.
13. Install second wearplate down against the bottom impeller.
14. Permatex top side of cam and cam screw threads. Line up pins in cam with holes in wearplate and install cam and secure with cam screw.
15. Lubricate remainder of the impeller bore and install second impeller with a rotary motion until splines engage. Then push into bore until it seats against the wearplate.
16. Install gasket and end cover and secure with end cover screws.

WARRANTY: All products of the company are sold and all services of the company are offered subject to the company's warranty, terms and conditions of sale, copies of which will be furnished upon request.

JABSCO PRODUCTS **ITT**

Marine and Recreation Components Division
International Telephone and Telegraph Corporation
1485 Dale Way, Costa Mesa, California 92626
Telephone (714) 545-8251