

a xylem brand

ENGINE COOLING SELF-PRIMING PUMP

FEATURES

Body:	Bronze
Bearing Housing:	Bronze
Impeller:	Jabsco Neoprene Compound
Shaft:	Stainless Steel
Shaft Seal:	Carbon-Ceramic Face Type
Bearings:	Sealed Ball Bearing
Ports:	1-1/4" ID Hose
Pulley:	6-1/2" Full Grip "A" Belt
Weight:	7 lb (3.2 kg)

INSTALLATION AND OPERATION

The pump may be mounted in any position. The direction of rotation of the pump determines the location of the intake and discharge ports (refer to dimensional drawings). Before installing, rotate the pump shaft in the direction of the normal operating rotation of the engines on which the pump will be mounted. The mounting bracket used to support the pump must be designed to enable adjustment of the pump position for proper drive belt tension.

Attach the pump to the mounting bracket using 3/8" –16 hex head screws. The pump mounting holes are tapped to this thread size.

Put Pulley drive belt over both the drive pulley and the pump pulley. An "A" section pulley belt should be sufficient to drive the 18940-0010 pump. Position the pump to

	<p>WARNING Injury hazard. Exposed pulleys and belts can cause injury. Install shield around pulleys and belts. Stay clear while machinery is operating.</p>
---	--

allow 1/2" deflection of the drive belt midway between the engine and pump pulleys. Secure the pump mounting brackets. Attach 1-1/4"ID hose to the ports and clamp using two stainless steel band clamps per port (be sure to attach the water intake line to the proper pump port).

Be sure that all suction lines are airtight so that the pump will self-prime. Start the engine and run at low speed. This pump depends on the water for lubrication. DO NOT RUN DRY for more than 30 seconds. Lack of water will damage the impeller. This pump is designed for



Model 18940-0010

liquids between 45° and 180°F. Pumping colder water will shorten impeller life.

Cooling system should be designed so the cooling pump operates with a maximum of 15 psi output pressure.

WINTERIZING

Drain the pump by loosening the impeller housing bolts and loosening the housing. Flush cooling system with an ethylene glycol base antifreeze. NOTICE: Do not use a petroleum based rust inhibitor in the pump. Pump damage can result.

APPLICATIONS

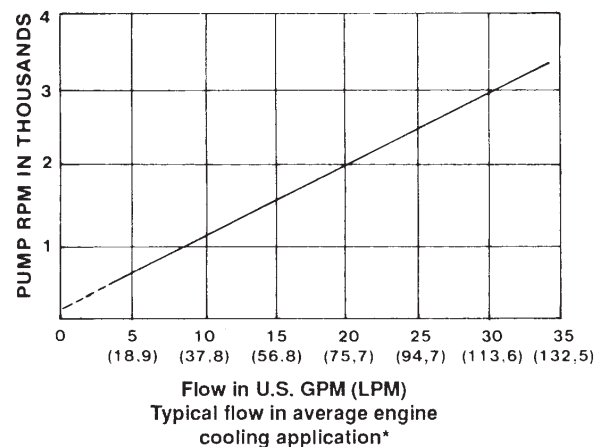

- Marine engine cooling
- Replaces Sherwood model G-5 for Chrysler engines LM 318, LM 340, LM 360, LM 383, LM 400, LM 440
- Lehman 302, 351 C.I.
- Powerhouse Marine 302, 351 C.I.

SERVICE INSTRUCTIONS

DISASSEMBLY

1. Remove the three impeller housing screws (Key 13).
2. Slide impeller housing (Key 2) off the bearing housing (Key 3) and shaft (Key 4) assembly.
3. Grasping hub of impeller (Key 1) with pliers, remove it from impeller housing.
4. Remove cam screw (Key 12) from the impeller housing. Slide the cam (Key 6) out of the impeller housing.
5. Remove the O-ring (Key 7) from the impeller housing groove. **TO REMOVE SEAL ASSEMBLY, THE SHAFT AND BEARING ASSEMBLY MUST BE REMOVED FROM THE BEARING HOUSING (KEY 3).**
6. Drive roll pin (Key 11) out of the pulley and shaft subassembly.
7. Loosen set screw and remove pulley (Key 5) and key (Key 16) from shaft.
8. Remove the retaining ring (Key 10) out of the bearing housing (Key 3).
9. Lightly tap the spline end of the shaft. Shaft and ball bearings (Key 9) should slide out of the bearing housing. **BE CAREFUL NOT TO DAMAGE SPLINE END OF SHAFT.**
10. Ceramic portion of the seal (Key 8) assembly normally will stay on the shaft. **THE BRASS/CARBON PORTION OF THE SEAL SHOULD HAVE REMAINED IN THE BEARING HOUSING.** Lightly press this portion from the pulley end of the bearing housing toward the impeller end of the bearing housing.
11. Press ball bearings (Key 9) off the shaft by supporting each bearing on its inner race to prevent damage.

ASSEMBLY

1. Clean and inspect all components for wear or damage. Replace all components where needed.
2. Lightly lubricate pump shaft (Key 4) and press bearings (Key 9) onto shaft by applying force to inner race of the bearing. **DO NOT APPLY FORCE TO OUTER RACE OF BEARING.**
3. Slide ceramic (white) portion of seal (Key 8) onto spline end of shaft with large white face toward spline end.
4. Lightly press the brass/carbon portion of the seal into the bearing housing (Key 3); be careful not to damage the carbon face of the seal. Brass face should face toward impeller end of pump and be pressed flush with bottom of counter-bore.
5. Lightly press shaft, bearing and shaft seal (ceramic portion) subassembly into bearing housing; be careful not to damage shaft end or seal components during this assembly.
6. Replace bearing retaining ring (Key 10) into bearing housing.
7. Slide pulley (Key 5) onto shaft. Make sure that roll pin hole in shaft lines up with hole in pulley.**
8. Drive roll pin (Key 11) into pulley and shaft and tighten set screw.
9. Apply a thin coat of sealant to convex side of cam (Key 6) and threads of cam screw (Key 12), and fasten cam to impeller housing.
10. Slide impeller (Key 1) onto shaft spline and place spline seal in impeller.
11. Slide impeller (Key 7) into groove in impeller housing and cam subassembly. Lubricate impeller bore. With a twisting motion, slide the impeller housing over the impeller. Be sure the direction the impeller blades are bent matches the direction of normal engine and pump rotation.
12. Fasten impeller housing to bearing housing with the three machine screws and washers (Key 13 and 14).
13. **TEST** pump following instructions under **Installation and Operation section.**

**If the roll pin hole cannot be aligned through pulley and shaft, drill a new 1/8" hole for roll pin at an angle 45° from original hole. Center punch pulley hub or file a flat spot on hub to ease start of drilling procedure.

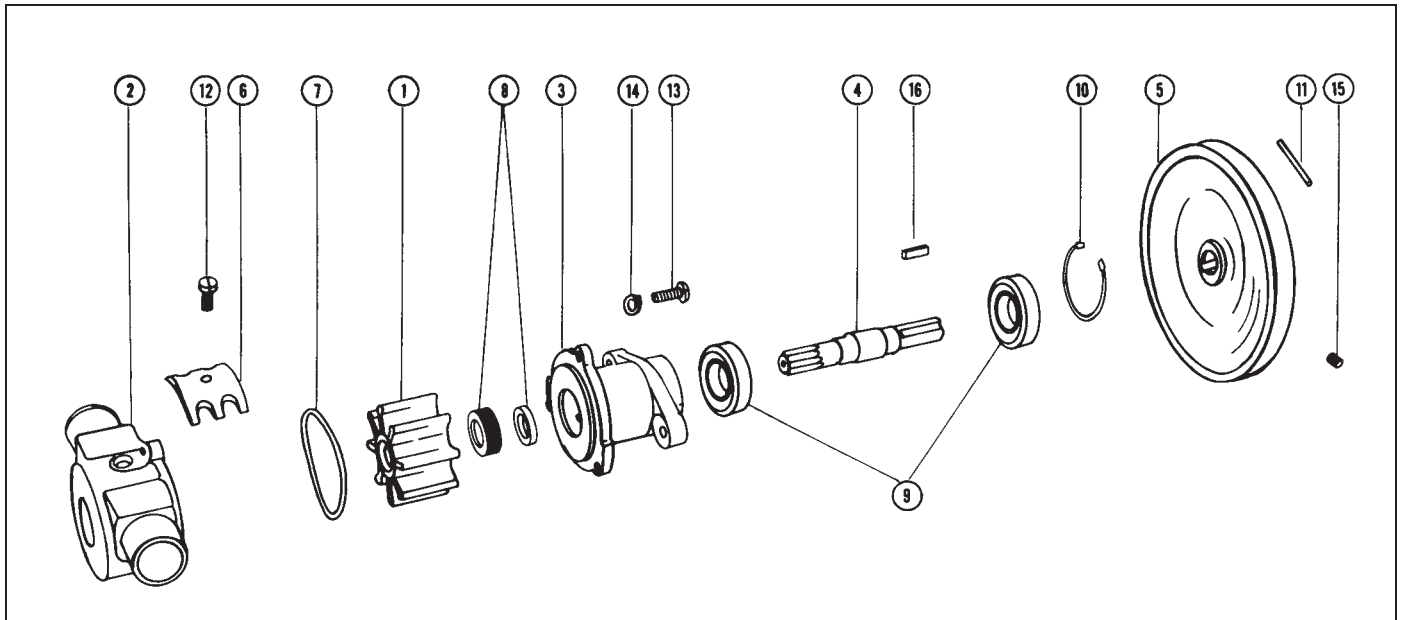

PARTS LIST

Key	Description	Qty.	Part Number
1	Impeller and Spline Seal*	1	11979-0001
2	Impeller Housing	1	18944-1000
3	Bearing Housing	1	18943-1000
4	Shaft	1	18836-1000
5	Pulley	1	18753-0006
6	Cam	1	10182-0000
7	O-Ring*	1	18753-0005
8	Seal*	1	96080-0080
9	Ball Bearing	2	92600-0120
10	Retaining Ring†	1	See Hrdw. Kit
11	Roll Pin†	1	See Hrdw. Kit
12	Cam Screw	1	91004-0090
13	Screw Kit (3 ea. with Washers)	1	18753-0001
14	Split Washer		See Screw Kit
15	Set Screw†	1	See Hrdw. Kit
16	Key†	1	See Hrdw. Kit
	Service Kit	1	90184-0001
	Hardware Kit	1	18753-0010

*Included in Service Kit

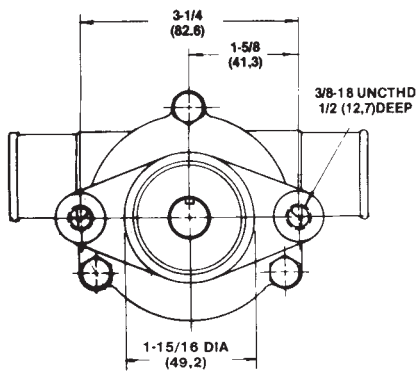

PULLEY NOT SHOWN

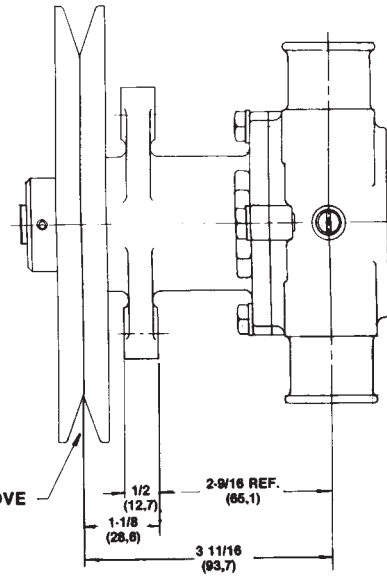

"A" BELT PULLEY GROOVE

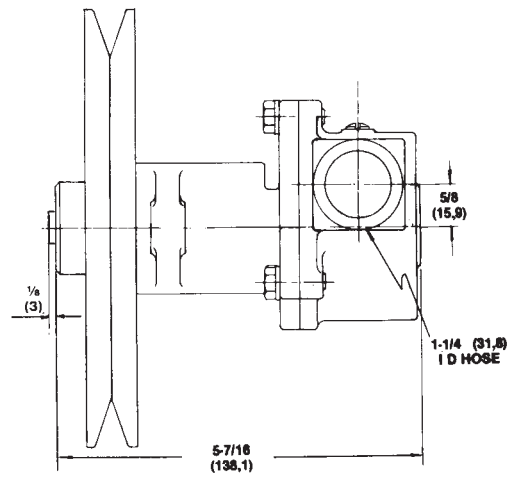
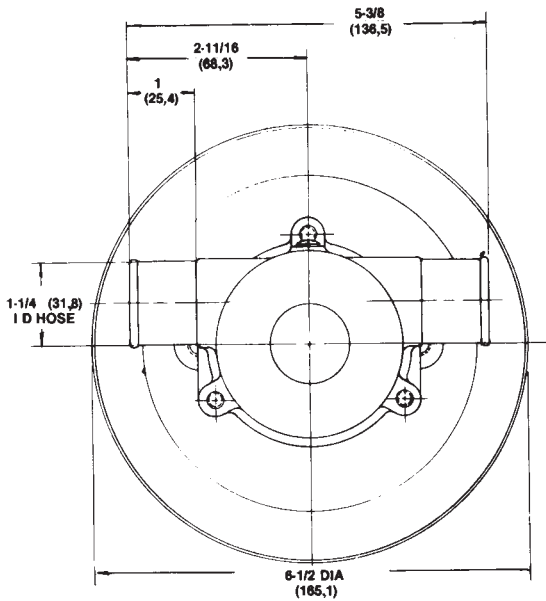
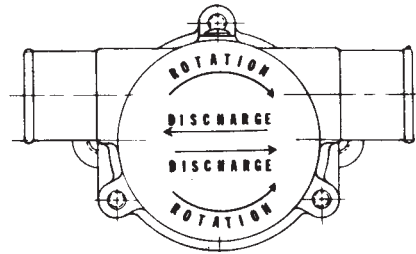

THE PRODUCTS DESCRIBED HEREIN ARE SUBJECT TO THE JABSCO ONE YEAR LIMITED WARRANTY, WHICH IS AVAILABLE FOR YOUR INSPECTION UPON REQUEST.

www.xylemflowcontrol.com

Jabco, 100 Cummings Center, Ste. 535-N, Beverly, MA 01915
Tel: +1 978 281 0440 Fax: +1 978 283 2619

Jabco, Bingley Road, Hoddesdon, Hertfordshire, EN11 0BU
Tel: +44 (0) 1992 450 145 Fax: +44 (0) 1992 467 132

NHK Jabco Co Ltd, 3-21-10, Shin - Yokohama Kohoku-ku, Yokohama 222
Tel: +81 (0) 45 475 8906 Fax: +81 (0) 45 475 8908

Jabco GmbH, Oststraße 28, 22844 Norderstedt
Tel: +49 (0) 40 53 53 73 0 Fax: +49 (0) 49 53 53 73 11

Jabco Italia, s.r.l., Via Tommaseo, 6, 20059 Vimercate, Milano
Tel: +39 039 685 2323 Fax: +39 039 666 307

USA

UK

JAPAN

GERMANY

ITALY



a xylem brand