

***For Your Convenience: This Kubota  
File Is Shared By Diesel Parts Direct***



**YOUR ONE STOP SUPERSTORE FOR DIESEL ENGINE PARTS**

**SHOP NOW**



INDUSTRIAL DIESEL ENGINE

**KUBOTA 05 SERIES (4-cylinder)**

**V1505-T-E3B**



### RATED POWER

**33.0kW @3000rpm**

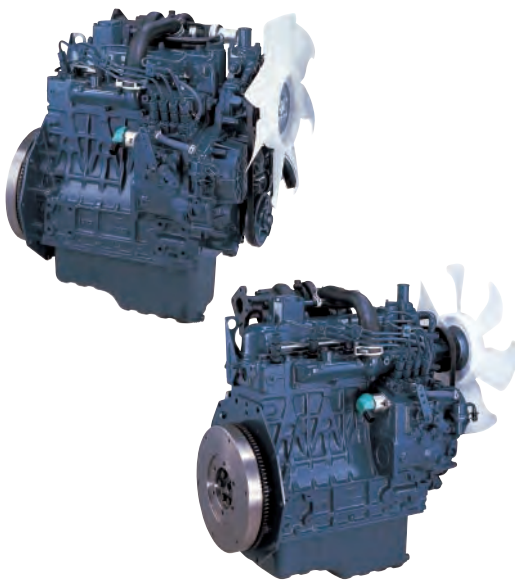

Photographs may show non-standard equipment.

### PERFORMANCE CURVE

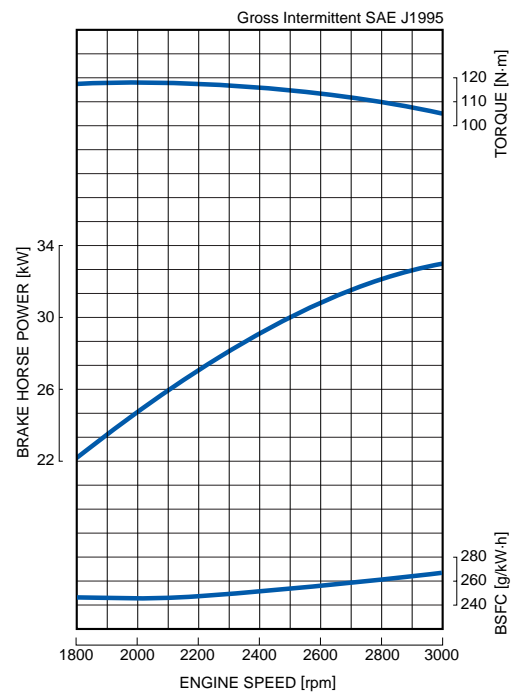

### FEATURES and BENEFITS

#### Emissions

- The V1505 Turbocharged engine complies with EPA Interim Tier 4 emissions regulations that are effective through the end of 2012. This engine also complies with EU Stage IIIA requirements that are effective through 2012 and beyond in the European market.

#### Durable Power

- The Kubota 05 Series is an established leader in its horsepower range and has been the preferred power source of various industrial equipment manufacturers.
- The V1505-T engine offers a seamless transition from Tier 2 to Interim Tier 4 by maintaining the same footprint and hardware mounting points with no performance changes from the Tier 2 engine.

#### Clean and Quiet Power

- The addition of a closed breather system meets EPA Interim Tier 4 requirements.
- Kubota's original E-TVCS (Three Vortex Combustion System) has been improved. The airflow, combustion chamber and piston recess were optimized to provide a 50% lower particulate matter (PM) level, the same stringent level as above the 37kW class (EPA Interim Tier 4 Option 1).

## GENERAL SPECIFICATION

Model		<b>V1505-T-E3B</b>
Emission Regulation		Interim Tier 4 / Stage III A
Type		Vertical 4-cycle Liquid Cooled Diesel
Number of Cylinders		4
Bore	mm (in)	78.0 (3.07)
Stroke	mm (in)	78.4 (3.09)
Displacement	L (cu.in)	1.498 (91.41)
Combustion System		IDI
Intake System		Turbocharged
Maximum Speed	rpm	3000
Output: Gross Intermittent	kW	33.0
	hp	44.2
	ps	44.9
Direction of Rotation		Counterclockwise Viewed on Flywheel
Oil Pan Capacity	L (gal)	6.7 (1.77)
Starter Capacity	V-kW	12-1.2 [US] / 12-1.4 [EU]
Alternator Capacity	V-A	12-40
Length	mm (in)	591.3 (23.28)
Width	mm (in)	433.0 (17.05)
Height (1)	mm (in)	621.0 (24.45)
Height (2)	mm (in)	232.6 (9.16)
Dry Weight	kg (lb)	114.0 (251.3)

\*Specification is subject to change without notice.

\*Output: Gross Intermittent SAE J1995

\*Dry weight is according to Kubota's standard specification.

When specification varies, the weight will vary accordingly.

## DIMENSIONS

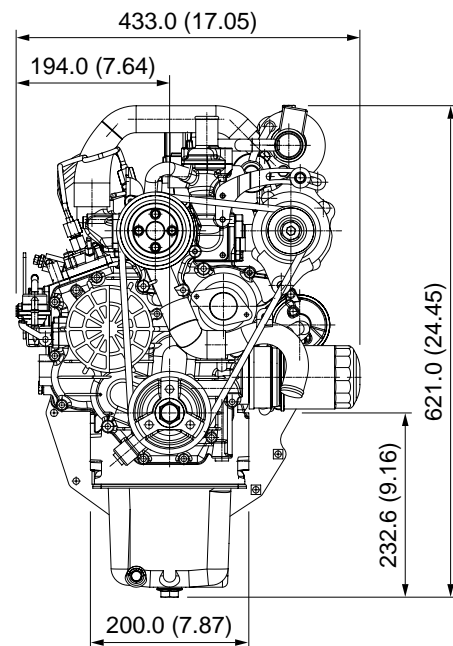
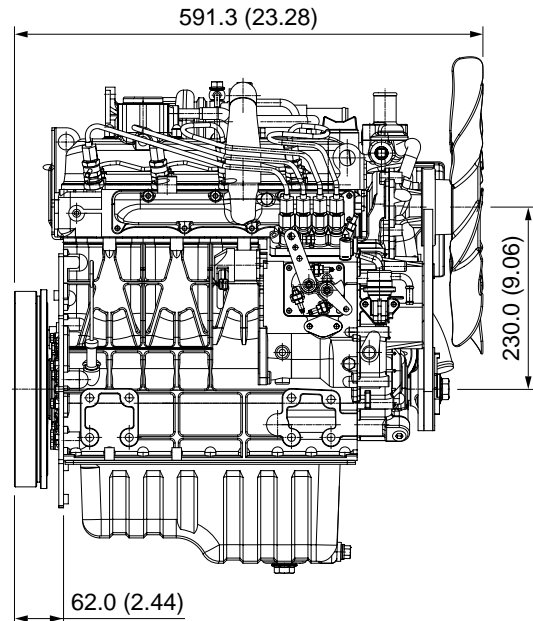

## KUBOTA Corporation

2-47, Shikitsuhigashi 1-chome, Naniwa-ku, Osaka, 556-8601 Japan  
Fax: 06-6648-3521

<http://www.engine.kubota.ne.jp>

Your Driving Force  
KUBOTA ENGINE